

Intelligent Dynamic Control Valves

Digital Balanced Precision Control Solution

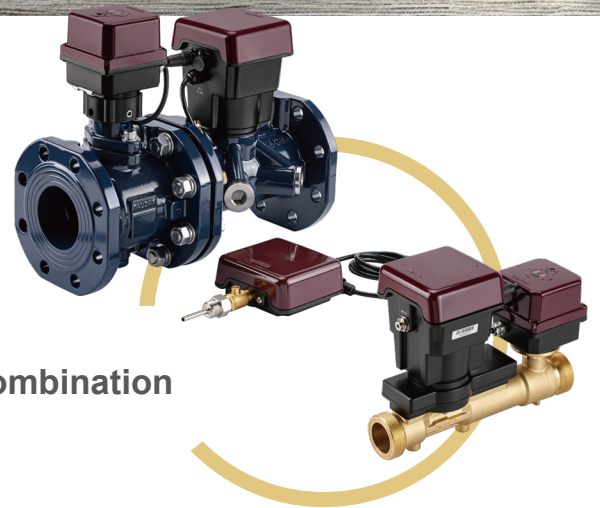

Global Flow Control Combination

TALOAR[®]

TALOAR INC
FLUID SYSTEMS, 2026

IDCV

Intelligent Dynamic Control Valve

The intelligent dynamic control valve is the core intelligent terminal of modern HVAC water systems. It integrates dynamic hydraulic balancing, precise flow measurement and regulation, cooling/heating energy metering, and intelligent interconnection. It fundamentally solves problems such as low efficiency and imbalance in traditional air conditioning water systems, and is key equipment for achieving high-efficiency energy saving, precise comfort, and digital operation and maintenance of buildings.

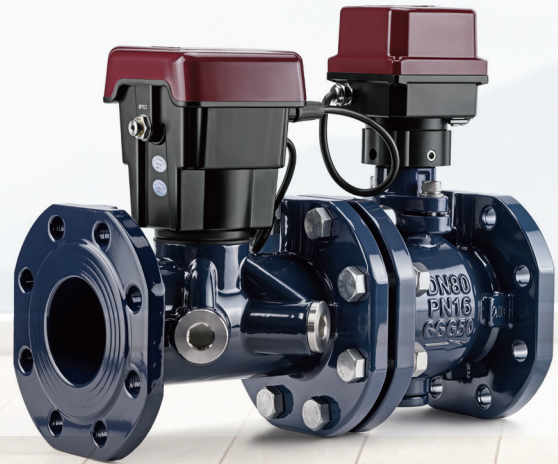

Free selection of multiple control modes

It integrates multiple control modes: valve position, flow, energy, differential pressure, temperature, and temperature difference, all freely switchable.

Optional temperature difference & temperature limitation

Flow, energy, and differential pressure modes can be used in combination with temperature difference and temperature functions. The system always operates at optimal temperature difference or return water temperature to optimize chiller performance.

Easy Commissioning

Bluetooth connection to mobile APP enables non-contact parameter setup, greatly improving commissioning efficiency.

Optional management platform available

Local or cloud deployment, remote monitoring and adjustment of system operating data, green operation and maintenance.

Automatic summer/winter mode switching

Automatically identifies operating conditions. One valve serves multiple functions in two-pipe systems, operating precisely per condition parameters to achieve stable energy saving.

Unique Pressure Function

By monitoring operating parameters such as valve position and circuit resistance, it calculates reliable pump head setpoints to reduce pump energy consumption. This function is realized via the management platform.



CORE PERFORMANCE

Valve Position Indication

Valve opening indicator on the actuator top for clear and direct status display.

Valve Position Hold Function

When the pump stops, the valve automatically holds its position, reducing rebalancing time and shortening chiller startup time.

Diverse Communication Modes

Digital: Modbus, MQTT
Analog: 0(2)–10V and 0(4)–20mA

Built-in LCD Screen

The control module is equipped with an LCD screen for scrolling data display.

High Measurement Accuracy & Stability

Ultrasonic flow measurement ensures proper flow for each device and achieves precise control.

Diagnostic Function

Continuously measures data to detect system issues in advance. Pressure monitoring helps locate pipe blockages and enhance O&M efficiency.

FLOW CONTROL ACCURACY

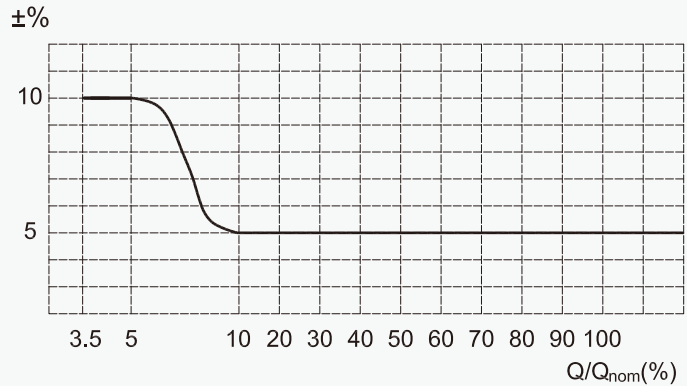

TECHNICAL SPECIFICATION

Application

Air conditioning and heating systems, domestic hot water systems.

Functions

- Data Collection: Collect and upload data including flow rate, temperature, temperature difference, pressure, differential pressure, energy and valve position.
- Valve parameters can be set and read remotely or via Bluetooth.
- Automatic switching between winter and summer operating modes.
- Valve jam detection and protection
- Fault reset
- Valve position indication
- Manual / auto mode switching; configurable via APP/remote with or without power cycle

Medium

Neutral fluids such as water and glycol

Dimension

DN20-DN200 (For sizes above DN200, please consult the manufacturer)

Pressure Class

PN16

Temperature Range

Medium Temperature: 0~100°C
Ambient Temperature: 0~55°C
Storage Temperature: -20~70°C

Operating Differential Pressure

Max Differential Pressure PV_{max}: 350 kPa
Closing Differential Pressure: 600 kPa

Materials

Body: Brass
Valve Core: Stainless Steel
Stem: Brass
Seat: PTFE
Seal: EPDM
Control box and actuator housing: ABS and Polycarbonate
Temperature probe: Stainless Steel
Pressure probe: Stainless Steel

DN65-200
Body: Ductile iron, stainless steel
Core: Stainless steel
Stem: Stainless steel
Seat: PTFE
Seal: EPDM
Control box & actuator housing: ABS & polycarbonate
Temperature probe: Stainless steel
Pressure probe: Stainless steel

Temperature and Pressure Sensor
Housing: ABS and Polycarbonate
Probe: Stainless Steel

Measurement Accuracy

Flow: ±2% (≥3.5% Q_{nom})
Compliant with MID-Class 2 EN1434
Temperature: PT1000 Class AA
Pressure: 0.5% FS
FS: Full Scale, 1600kPa

Flow Control Accuracy

±5% (≥10% Q_{nom})
±10% (3.5-10% Q_{nom})

Flow Ranges

Recommended Flow Range for Each Pipe Diameter (Q_{min}-Q_{nom})

DN20: 85-2400 L/h
DN25: 150-4300 L/h
DN32: 200-5700 L/h
DN40: 300-8600 L/h
DN50: 500-14300 L/h
DN65: 1050-30000 L/h
DN80: 1500-43000 L/h
DN100: 2600-74000 L/h
DN125: 3700-106000 L/h
DN150: 5300-152000 L/h
DN200: 9000-257000 L/h
Q_{min}: Minimum controllable flow, 3.5% of Q_{nom}

Q_{nom}: Recommended maximum set flow
DN ≤ 50: Pressure loss < 24 kPa
DN ≥ 65: Pressure loss < 30 kPa
Actual maximum flow Q_{max} may exceed Q_{nom}; valve pressure loss must be verified in such cases.

Leakage Rate

Zero leakage (Class V per EN 60534-4)

Control Valve Characteristics

Equal percentage and linear adjustable

Operating Voltage

24VDC±10% (DN≤150)
Note: Per EN 61558-2-6, the 24VDC power supply must be provided through a safety isolating transformer.
220VAC±10% (DN200)
50/60 Hz ±5 Hz
Built-in moisture-proof resistor

Power

Operating: < 15W (DN≤150)
< 110W (DN200)
Standby: < 2W

Protection Class

IP54
(Compliant with EN 60529)

Communication

Bluetooth
MODBUS RTU
MODBUS TCP

Input / Output

Communication: MODBUS
Analog: 0(2)-10V
0(4)-20mA
Switch control: Dry contact

Actuating Time

Time from 0-90° < 60s (adjustable via APP)

PRODUCT SPECIFICATION

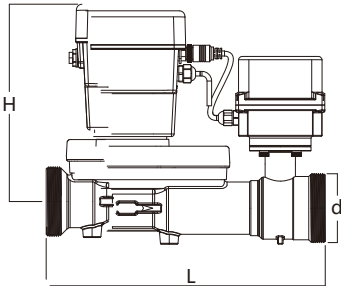

IDCV 300D-P/T/Q
Threaded connection, EN ISO 228-1

DN mm	d mm	L mm	H mm	Kvs	Kg
20	G1	300	198	5	2.3
25	G1¼	300	201	9	2.6
32	G1½	300	205	12	4.1
40	G2	300	209	18	4.6
50	G2½	300	214	30	5.5

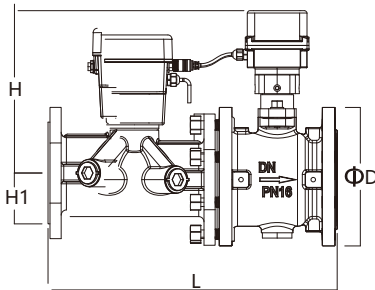

IDCV 500F-P/T/Q, IDCV 100F-P/T/Q
Flanged connection, EN 1092-2

DN mm	ΦD mm	L mm	H mm	H1 mm	Kvs	Kg ₁	Kg ₂
65	185	343	240	75	55	19.0	20.5
80	200	401	255	92	79	26.5	28.5
100	220	440	270	101	137	32.0	34.5
125	250	470	283	115	195	42.0	45.5
150	285	555	295	135	280	58.0	62.5
200	340	655	565	159	470	108	111

IDCV X00X-P: With full parameter acquisition and control functions for flow, temperature, pressure, and energy; standardly equipped with water supply pressure and temperature sensors, cable length: 1.2 m;

IDCV X00X-T: With parameter acquisition and control functions for flow, temperature, and energy; standard product, equipped with water supply temperature sensor, cable length: 1.2 m;

IDCV X00X-Q: With dynamic flow, valve position and other functions;

Kg₁: Weight of 500 series ductile iron version; Kg₂: Weight of 100 series stainless steel version.

PRESSURE/TEMPERATURE SENSOR

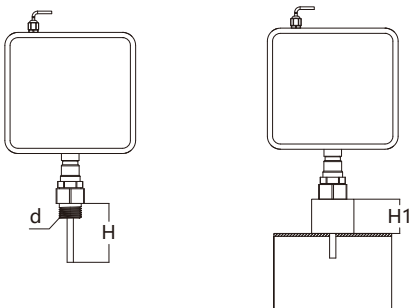

Size mm	d mm	H mm	H1 mm
DN20-25	G½	55	40-45
DN32-50	G½	55	30-35
DN65-125	G½	65	20-25
DN150-200	G½	100	20-25

PRODUCT SELECTION

1. Under the premise of a reasonable specific resistance design, it is recommended to select the valve with the same nominal diameter as the pipe.
2. For applications such as air handling units, fresh air units, and plate heat exchangers, valve sizing can be calculated based on the flow rate.

BASIS OF CALCULATION

*Taking water as the medium with a density of 1000 kg/m³ as an example. For other media, please consult the manufacturer.

1. With known design flow rate and selected pipe size, the pressure drop of the intelligent valve can be calculated using the following formula.

$$\Delta P_v = 100 \left(\frac{Q}{Kvs} \right)^2$$

ΔP_v , kPa

Q, m³/h

Kvs: Flow coefficient of the selected pipe size

If a higher pressure drop is allowed, the selected flow rate may exceed the recommended range in this catalog.

Example: Design flow rate = 20 m³/h, selected size DN80
resulting valve pressure drop

$$\Delta P_v = 100 \left(\frac{20}{79} \right)^2 = 6.4 \text{ kPa}$$

2. With known design flow rate and maximum allowable valve pressure drop, the Kv value of the intelligent valve can be calculated using the following formula.

$$Kv = 10 \frac{Q}{\sqrt{\Delta P_v}}$$

ΔP_v , kPa

Q, m³/h

Kvs: Flow coefficient of the selected pipe size

After calculating the Kv value, select the closest Kvs from the product catalog and verify the pressure drop.

The pressure drop shall not exceed the design allowable value. If not satisfied, the next larger pipe size shall be selected.

Example: Design flow rate = 30 m³/h, maximum allowable pressure drop = 25 kPa
resulting valve pressure drop

$$Kv = 10 \frac{30}{\sqrt{25}} = 60$$

According to the catalog, select DN65 with Kvs=55 for verification

$$\Delta P_v = 100 \left(\frac{30}{55} \right)^2 = 29.8 \text{ kPa} > 25 \text{ kPa}$$

DN65 does not meet the maximum pressure drop requirement; select the next size up, DN80.



PRODUCT APPLICATION

Applied to single terminal units, such as air handling units (AHUs), plate heat exchangers, etc.

- Used to replace motorized control valves, dynamic balancing motorized control valves, etc. Flow mode or energy mode is recommended.
- Temperature difference and temperature limit options can be enabled to further widen the temperature difference, bringing the system closer to the design operating conditions.
- Provides cumulative terminal operation data, facilitating the chiller's staging control and the pump's dynamic head adjustment.
- For two-pipe systems, two sets of parameters can be configured to maintain balanced operation under winter and summer conditions, enabling energy-efficient operation while ensuring comfort.

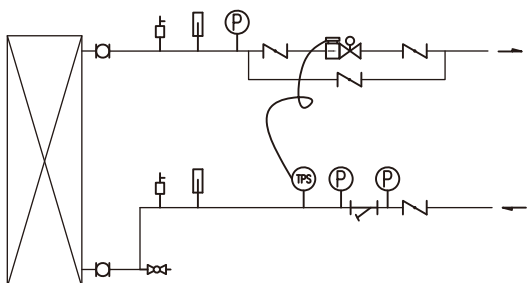

Applied to multi-terminal systems, such as fan coil unit branches, main pipes for floor heating, building inlets, etc.

- Used to replace static balancing valves, differential pressure control valve assemblies, etc. Differential pressure mode is recommended to ensure the design flow rate is achieved at the most disadvantaged point.
- Temperature difference and temperature limit options are available (consult the manufacturer for parameter settings) to further widen the temperature difference, bringing it closer to the design operating conditions.
- Provides cumulative terminal operation data, facilitating chiller staging and dynamic pump head adjustment.
- For two-pipe systems, two sets of parameters can be configured to ensure balanced operation under winter and summer conditions, enabling energy-efficient operation while maintaining comfort.

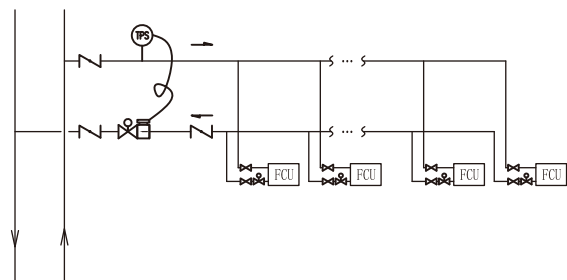

APPLIED VALUE

By using TALOR intelligent dynamic control valves, energy-efficient operation of the system can be achieved while ensuring comfort through the following measures.

1. Accurate parameter setting enables automatic system balancing, improves comfort, and avoids low system energy efficiency caused by excessive total flow.

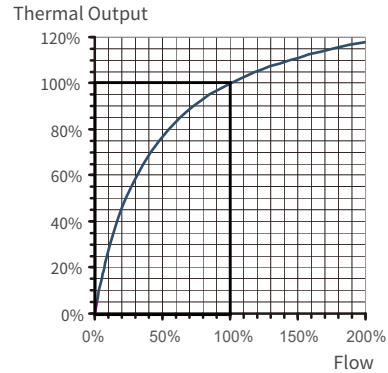
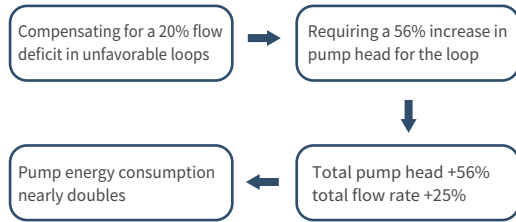

It is incorrect to compensate for insufficient flow at the terminal units by increasing the pump head. This leads to a significant increase in pump energy consumption.

Furthermore, excessive flow in favorable loops provides only a limited improvement in heat transfer (as shown in the upper right diagram), which in turn increases the energy consumption of the chiller.

2. By managing heat exchange temperature differences to approach design values as closely as possible, system efficiency is improved.

Flow can be reduced by approximately 30%. Based on the pump power formula $P \propto Q^3$, pump energy consumption is reduced by about 65%. Since pumps account for 7–17% of total refrigeration system energy consumption, this measure saves 4–11% of total energy.

3. Eliminates the reduction in chiller COP caused by low return water temperature on the water side.

Each 1°C drop in evaporation temperature reduces COP by 3–3.5% and increases total energy consumption by 1–2.5%.

4. Clear total energy consumption data at terminals enables on-demand cooling and heating, supporting optimal chiller staging and high-efficiency operation.

With proper staging control, chiller energy consumption is reduced by 10–20%.

5. Adaptive parameter switching between winter and summer operating conditions allows the system to run with dedicated settings for each season, enabling more refined operation.

One valve serves multiple purposes, overcoming inherent limitations of two-pipe air conditioning systems.

6. Non-contact APP or remote commissioning improves efficiency and shortens commissioning time.

Commissioning results are visualized and traceable, supporting continuous optimization.

7. Diagnostic functions support scientific operation and maintenance, enabling dynamic management and early fault detection and correction.

Improves service quality and reduces operation and maintenance costs.

INSTALLATION

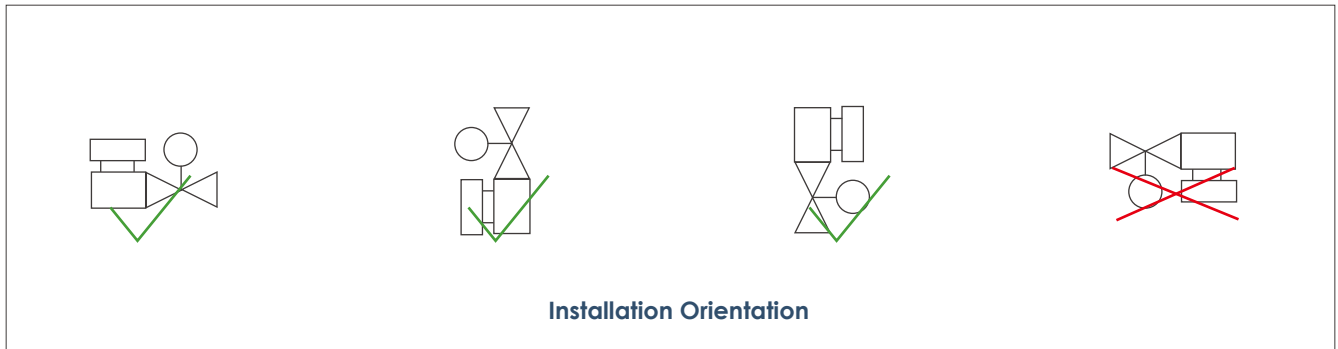
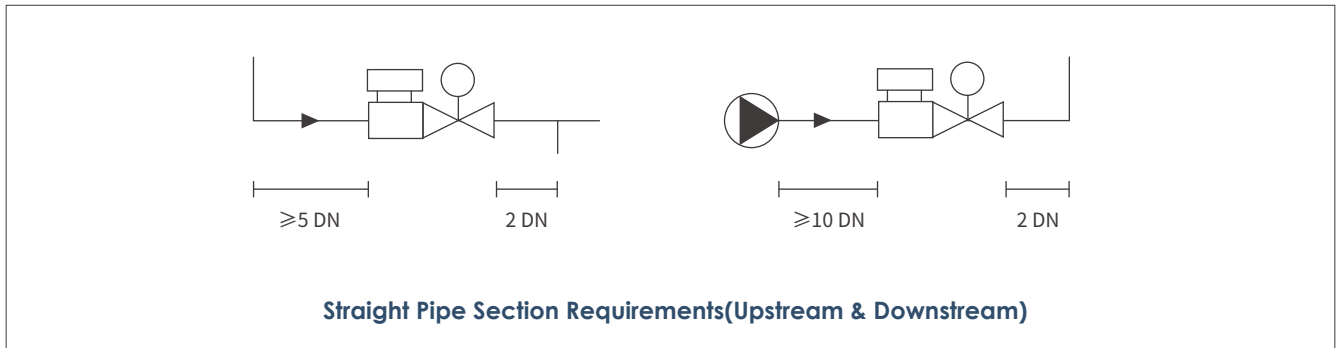
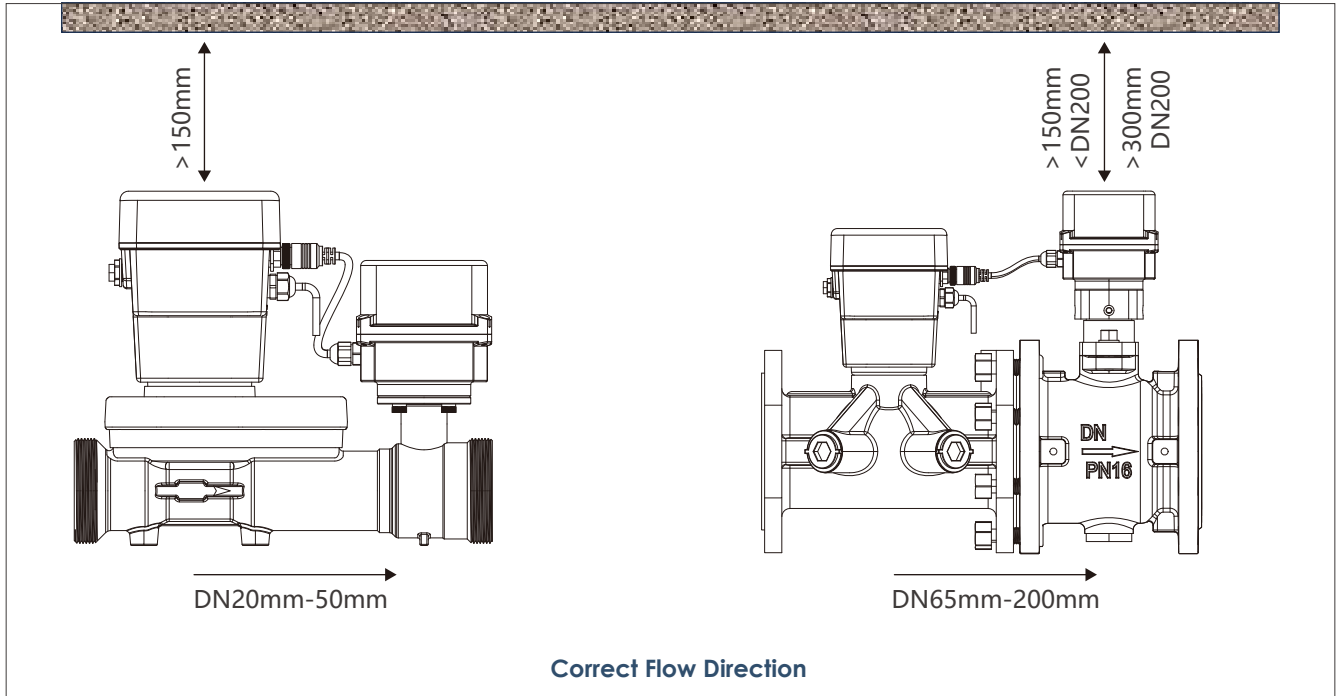

Installation Location

The valve is recommended for indoor installation. For outdoor installation, a sun & rain shield must be installed to avoid direct sunlight and water ingress.

WIRING DIAGRAM

DN ≤ 150mm

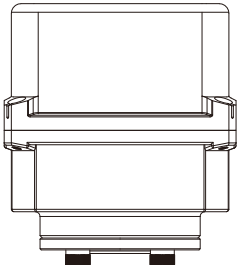

Red: 24VDC+

Black: COM

Green: RS485+

Yellow: RS485-

Purple: Analog input, 0(2)-10V,0(4)-20mA

Orange: Analog output, 0(2)-10V,0(4)-20mA

White: PT1000 3rd temp (optional)

Gray: PT1000 3rd temp (optional)

Blue: Switch control, activated when shorted to COM

DN200mm

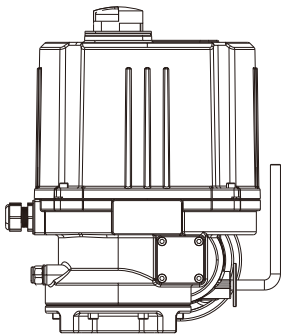

Black: COM

Green: RS485+

Yellow: RS485-

Purple: Analog input, 0(2)-10V,0(4)-20mA

Orange: Analog output, 0(2)-10V,0(4)-20mA

White: PT1000 3rd temp (optional)

Gray: PT1000 3rd temp (optional)

Blue: Switch control, activated when shorted with the red wire

Red: Switch control, activated when shorted with the blue wire

Red: Live wire (L)

Blue: Neutral wire (N)

Yellow-green: Protective earth wire (PE)

Fire Protection

- Resilient Wedge Gate Valve
- Indicator Post
- Butterfly Valve
- Fire Hydrant
- UL/FM



Oil Refining

- Gate Valve
- Globe Valve
- Trunnion Ball Valve
- High Performance Butterfly Valve
- Plug Valve
- API 609 API 6D

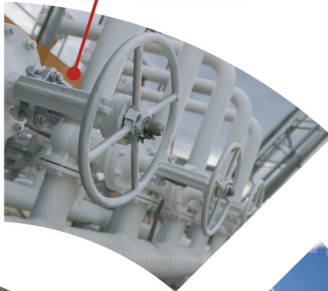

Power Plant

- Metal Seal Ball Valve
- Gate Valve
- Globe Valve
- Needle Valve
- CS, FS, SS



Shipping

- Bronze Valve
- Butterfly Valve
- Gate Valve
- Ball Valve
- Check Valve



Our Business



Water Treatment

- Flanged Butterfly Valve
- Knife Gate Valve
- Check Valve



HVAC Systems

- Hydraulic Balancing Valve
- Differential Pressure Valve
- Motorized Valve
- Temperature Control
- Bronze Valve & Iron Valve



Chemical

- Bellows Globe Valve
- Angle Valve
- Metal Seal Ball Valve
- High Performance Butterfly Valve



Irrigation

- Solenoid Control Valve
- Pressure Reducing Valve
- Pressure Relief Valve
- Diaphragm Valve
- Butterfly Valve
- Gate Valve





TALOR[®]

TALOR INC.,

1220N.Market Street,
Delaware,USA.
PHONE: +1/302.327.8999
www.taloor.com